

Calliope mini rev 2.0  
 Last Change: 06.07.2018  
 www.schleicher.berlin

Calliope mini rev2.1
01.03.22 17:58
Sheet: 1/2

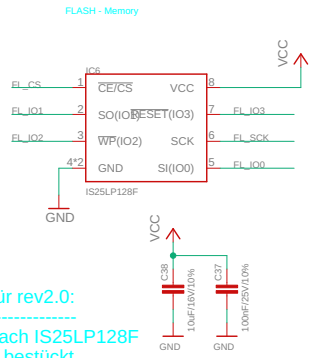

ÄNDERUNGEN für rev2.0:

IC6 von M45PE nach IS25LP128F  
 C37 und C38 nun bestückt  
 IC6 Pin 8, VCC nun an VCC statt USB\_VREG

ÄNDERUNGEN für rev2.1:

Signal Namen zu QSPI Signalen geändert

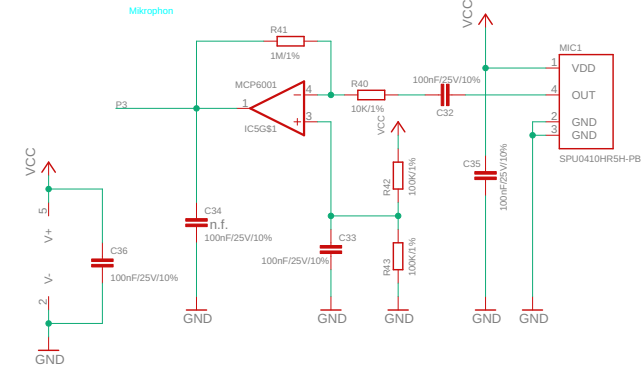
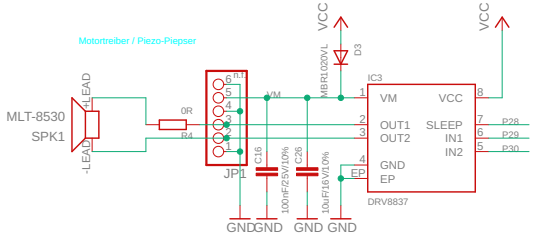

USB-Programmierinterface

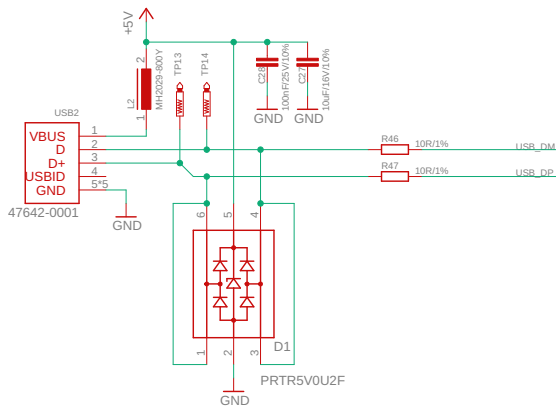

ÄNDERUNGEN für rev2.1:

Filter auf Datenleitungen entfernt

Interface processor + 3.3V power supply

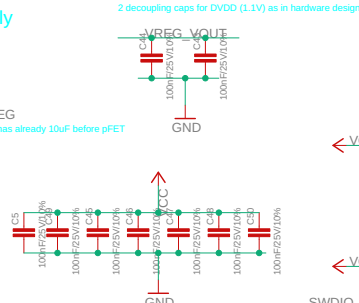
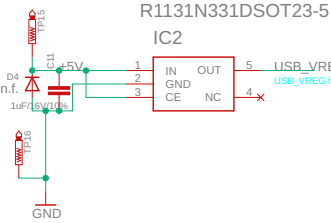

7 decoupling caps for VCC for IOVDD and VDDADC Pins as in hardware design place close to power pins.

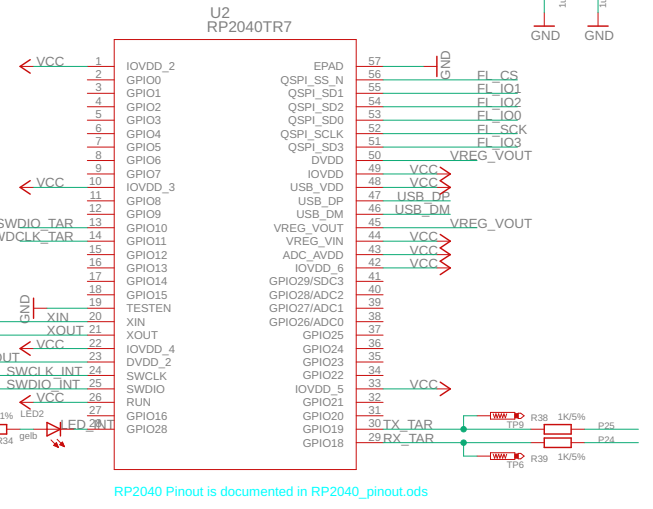
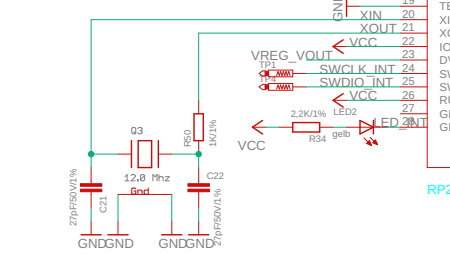

RP2040 Pinout is documented in RP2040\_pinout.ods

Calliope mini rev 2.1	Calliope mini rev2.1
Last Change: 01.03.22	01.03.22 17:58
Calliope gGmbH	Sheet: 2/2